

BABY SAFEMOUNT RANGE

of Tank, Hopper & Vessel Weighing Assemblies



3-3805

717272

717273

Features

- Interchangeable capacities from 1 to 7.5 tonnes.
- Easy to install and maintain.
- Design eliminates the need for tie rods and stay bars.
- Integral jacking bolts, for fast and easy installation.
- Low profile design.
- Five year warranty.
- Fabricated, nylon coated assembly, for exceptional durability.
- Very competitively priced.
- CE Approval.
- Option - CENELEC/BASEEFA certification EEx ia IIC T6.
- Option - Stainless steel construction.

717262-Uni

78-619542

Description

The **Safemount** range is now the industry standard for vessel, tank and hopper weighing. The unique design ensures simple, safe and accurate weighing.

ENGINEERING SPECIFICATIONS

BABY SAFEMOUNT RANGE

Specifications

Full Scale Output:	2mV/V Nom	Safe Overload:	150%
Creep (in 20 minutes):	0.05% max	Output Resistance:	700Ω ± 30Ω
Nonlinearity:	0.05% max	Zero Balance:	1% FS
Hysteresis:	0.05% max	Supply Voltage:	6-12 volts (DC or AC)
Non-Repeatability:	0.05% max	Max Voltage:	15v
Max Operating Temp:	+ 73°C	Insulation Resistance:	> 2000 MΩ
Min Operating Temp:	-10°C		

SELECTION GUIDE BY PART NUMBER

Capacity	Plated tool steel cell plastic coated mild steel assembly	Stainless cell + plastic coated mild steel assembly	Stainless cell + stainless assembly
1000kg	AW300/01000	AW303/01000	AW305/01000
2000kg	AW300/02000	AW303/02000	AW305/02000
3500kg	AW300/03500	AW303/03500	AW305/03500
5000kg	AW300/05000	AW303/05000	AW305/05000
7500kg	AW300/07500	AW303/07500	AW305/07500

The Loadcells for the above can be certified by BASEEFA to EEx ia IIC T6 under certificate number BAS99ATEX2067
For BASEEFA Certified product add 'X' at the end of the part no. e.g. AW300/0100X

All units in mm

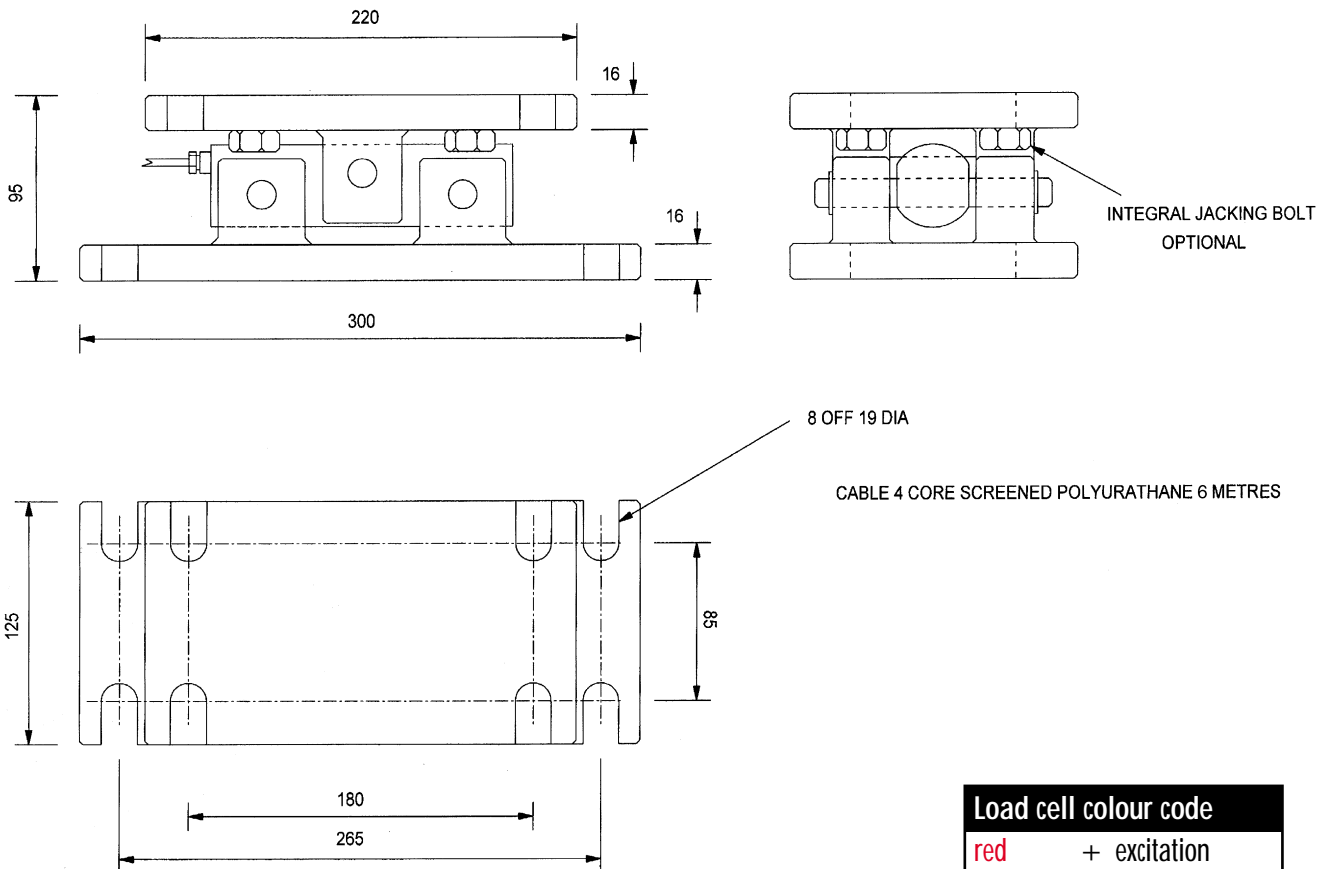

Load cell colour code	
red	+ excitation
blue	- excitation
green	+ signal
yellow	- signal



Groupe A à Z pesage
283, avenue du Bois de la Pie
BP 50334
Z.I. Paris Nord II
95941 ROISSY-CDG CEDEX
<http://www.aazpesage.fr>

Ile de France
Picardie
Normandie
Bretagne Nord
Bretagne Sud

Tél : 01 48 63 20 46
Tél : 03 44 12 13 50
Tél : 02 32 18 78 78
Tél : 02 96 74 60 93
Tél : 02 97 83 36 87

Fax : 01 48 63 21 64
Fax : 03 44 12 13 59
Fax : 02 32 18 26 16
Fax : 02 96 74 42 38
Fax : 02 97 37 52 87